

Technical documentation

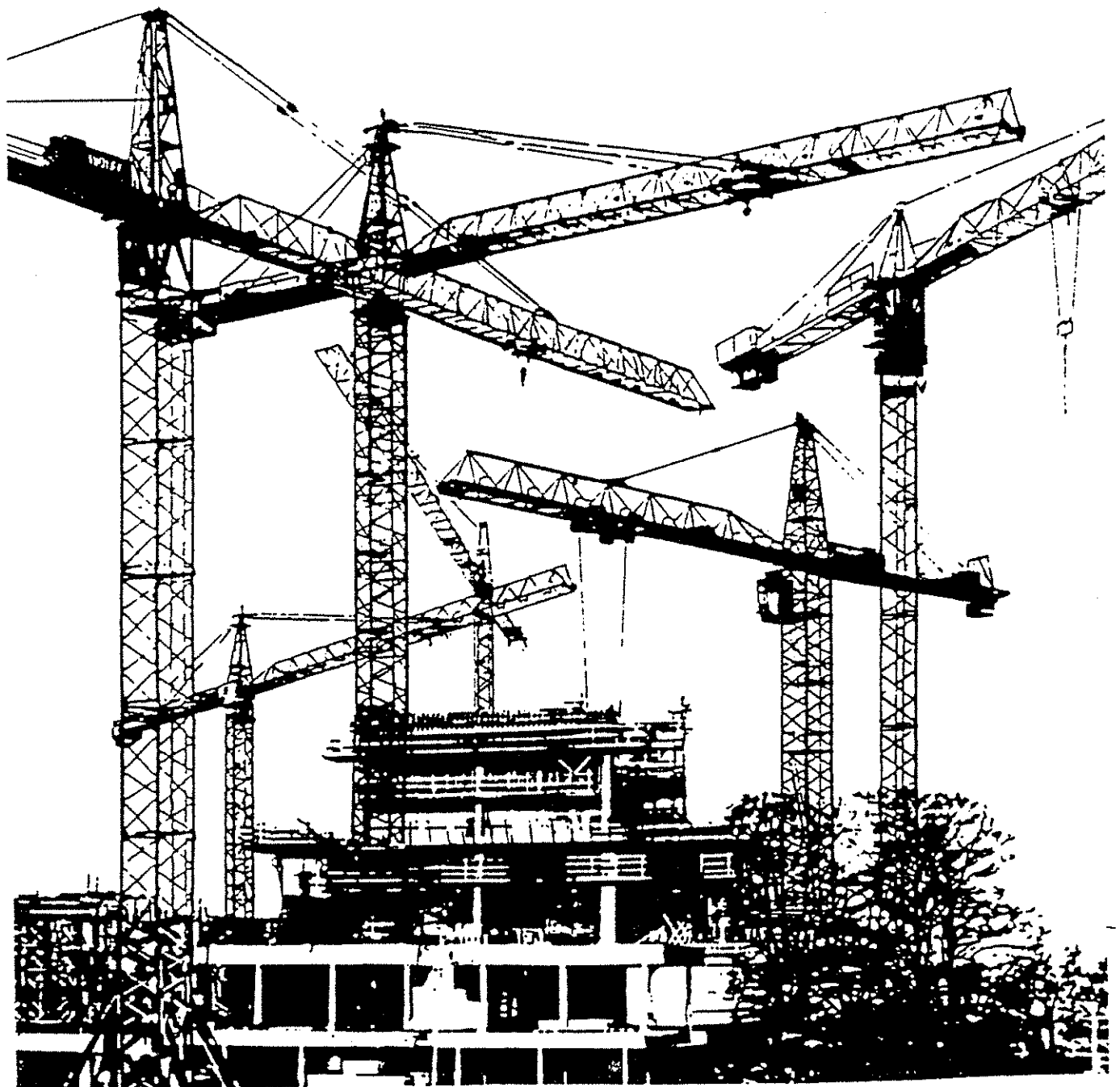

Wolffkran WK200EC

XIV 10499 E

TECHNICAL DATA

CAPACITY - RADIUS

		Radius [m]	2,6-	25	30	35	40	45	50	55	60	
jib length [m]												Capacity [t]
	30	2,6 - 20,42		9,59	7,8							
	35	2,6 - 20,36		9,56	7,78	6,50						
	40	2,6 - 20,20		9,45	7,72	6,45	5,50					
	45	2,6 - 20,00	12,0	9,38	7,6	6,37	5,43	4,7				
	50	2,6 - 19,00		8,85	7,18	6,0	5,10	4,41	3,85			
	55	2,6 - 16,73		7,65	6,18	5,14	4,35	3,74	3,25	2,85		
	60	2,6 - 13,23		5,81	4,65	3,82	3,2	2,72	2,33	2,01	1,75	

ARRANGEMENT OF COUNTERWEIGHTS

Jib [m]	25	30	35	40
to tower				
Tot. weight [t]		10,15	12,15	14,15
Jib [m]	45	50	55	60
to tower				
Tot. weight [t]	15,65	16,65	18,65	20,65

OPERATIONAL SPEEDS - MOTOROUTPUTS

Drive [Typ]	Operational speeds [Motion]		[m/min]	Reev-ing [falls]	max. Hook-travel [m]	Output [kW]	Total Output [kW]
Hw 6372	Hoisting up to	3,0t 6,0t	50,0 28,0	2	200	37	54,4
	Hoisting up to	6,0t 12,0t	25,0 14,0	4	100		
Tw 60 FSG	Travers. up to	6,0t 12,0t	80/40/20 40/20			6,0	
Dw - FG	Slewing		0,75 min ⁻¹			2 x 5,7	
Fw	Cranetravel		25			11-22	65,4-76,4

Wolffkran WK 200EC

XIV 10500E

TECHNICAL DATA

CAPACITY - RADIUS

		Radius [m]	2,6-	25	30	35	40	45	50	55	60	
Jib length [m]			12,0									Capacity [t]
	30	2,6 - 20,42		9,59	7,80							
	35	2,6 - 20,36		9,56	7,78	6,50						
	40	2,6 - 20,20		9,45	7,72	6,45	5,50					
	45	2,6 - 20,00		9,38	7,60	6,37	5,43	4,70				
	50	2,6 - 19,00		8,85	7,18	6,00	5,10	4,41	3,85			
	55	2,6 - 16,73		7,65	6,18	5,14	4,35	3,74	3,25	2,85		
	60	2,6 - 13,23		5,81	4,65	3,82	3,20	2,72	2,33	2,01	1,75	

ARRANGEMENT OF COUNTERWEIGHTS

Jib [m]	25	30	35	40
to tower				
Tot. weight [t]		10,15	12,15	14,15
Jib [m]	45	50	55	60
to tower				
Tot. weight [t]	15,65	16,65	18,65	20,65

OPERATIONAL SPEEDS - MOTOR OUTPUTS

Drive [Typ]	Operational speeds [Motion]	[m/min]	Reev-ing [falls]	max. Hook-travel [m]	Output [kW]	Total Output [kW]
Hw 6453	Hoisting up to 1,5t	100,0	2	200	45	62,4
	Hoisting up to 3,0t	63,0				
	Hoisting up to 6,0t	35,0	4	100	6,0	
	Hoisting up to 3,0t	50,0				
	Hoisting up to 6,0t	31,5				
	Hoisting up to 12,0t	17,5				
Tw 60 FSG	Travers. up to 6,0t	80/40/20				
	Travers. up to 12,0t	40/20				
Dw - FG	Slewing	0,75 min ⁻¹			2 x 5,7	
Fw	Cranetravel	25			11 - 22	73,4 - 84,4

Wolffkran WK 200 EC

XIV 10501 E

TECHNICAL DATA

CAPACITY - RADIUS

		Radius [m]	2.6-	25	30	35	40	45	50	55	60	
Jib length [m]												Capacity [t]
	30	2.6-20.42		9,59	7,8							
	35	2.6-20.36		9,56	7,78	6,50						
	40	2.6-20.20		9,45	7,72	6,45	5,50					
	45	2.6-20.00	12,0	9,38	7,6	6,37	5,43	4,7				
	50	2.6-19.00		8,85	7,18	6,0	5,10	4,41	3,85			
	55	2.6-16.73		7,65	6,18	5,14	4,35	3,74	3,25	2,85		
60	2.6-13.23		5,81	4,65	3,82	3,2	2,72	2,33	2,01	1,75		

ARRANGEMENT OF COUNTERWEIGHTS

Jib [m]	25	30	35	40
to tower →				
Tot. weight [t]		10,15	12,15	14,15
Jib [m]	45	50	55	60
to tower →				
Tot. weight [t]	15,65	16,65	18,65	20,65

OPERATIONAL SPEEDS - MOTOROUTPUTS

Drive [Typ]	Operational speeds [Motion]		Reev-ing [falls]	max. Hook-travel [m]	Output [kW]	Total Output [kW]
		[m/min]				
Hw 6663	Hoisting up to	2,0t 4,0t 6,0t	122,0 70,0 48,0	2	200	66 83,4
	Hoisting up to	4,0t 8,0t 12,0t	61,0 35,0 24,0	4	100	
Tw 60 FSG	Travers. up to	6,0t 12,0t	80/40/20 40/20		6,0	94,4-105,4
Dw - FG	Slewing		0,75 min ⁻¹		2 x 5,7	
Fw	Cranetravel		25		11-22	

4.185

Wolffkran 192 SL WK 200 EC

XIV 10360E

Hoisting rope: design according to DIN 15 020
kind of operation TWG 1 A_m

rope ϕ 16 mm, twistfree, impregnated

minimum breaking strength = 135 kN

Wolffkran rope: minimum breaking strength = 168.7 kN
calculated breaking strength = 216.7 kN
rated tensile strength = 1770 N/mm²

basic equipment:

rope length	1 x 258 m	42 m height under hook 60 m - jib
-------------	-----------	--------------------------------------

Upon decrease or increase of the height under hook of 4.5 m,
the necessary rope length is shortened or lengthened by 9 m with rope
in 2 falls and by 18 m with rope in 4 falls.

traversing ropes: design according to DIN 15 020
kind of operation TWG 1 A_m

rope ϕ = 8 mm, low twist, zinc coated

minimum breaking strength = 38 kN

Wolffkran rope: minimum breaking strength = 43 kN
calculated breaking strength = 57 kN
rated tensile strength = 1770 N/mm²

basic equipment:

rope length	1 x 70 m 1 x 118 m	60 m - jib
-------------	-----------------------	------------

Wolffkran 192 SL WK 200 EC XIV 10133 E

Counterweights

Material: concrete of min. BN 250 density $\rho = 2.4 \text{ t/m}^3$

All counterweights to be weighed again and to be clearly identified, stating the actual weight.
max. weight allowance $\pm 2\%$.

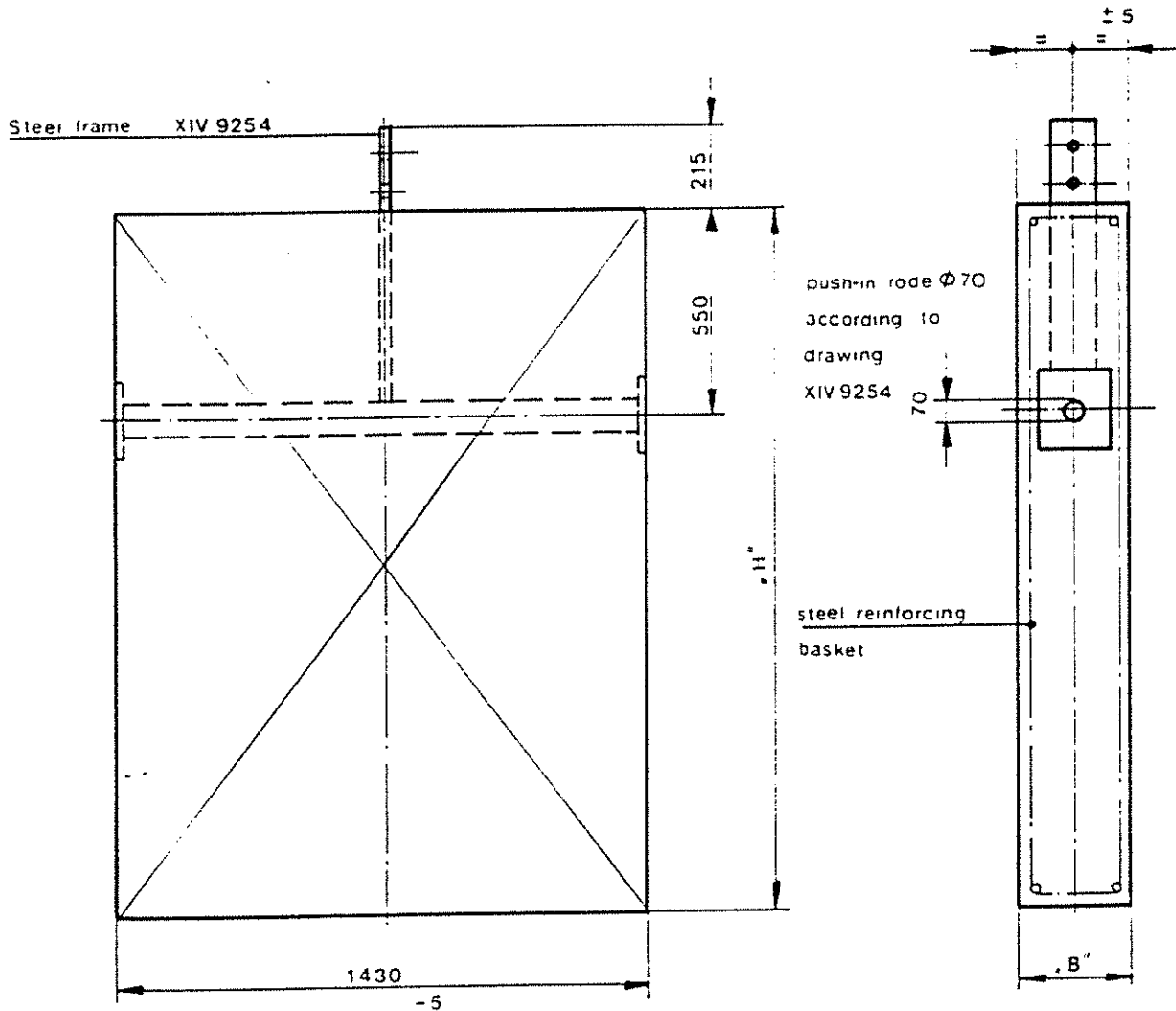

Weight Nr	t	Volume m^3	Width "B"	Height "H"
			mm	mm
1	5.5	2.27	840	1890
2	2.0	0.81	300	1890
3	1.0	0.40	250	1160

Quantity and arrangement of the counterweights
see technical data

12.11.82.16.1/2

Wolffkran 192 SLWK 200 EC XIV 10134 E

Counterweights (platform with machinery)

Material: concrete of min. BN 250 density $\rho = 2.4 \text{ t/m}^3$

All counterweights to be weighed again and to be clearly identified,
stating the actual weight.
max. weight allowance = 2%.

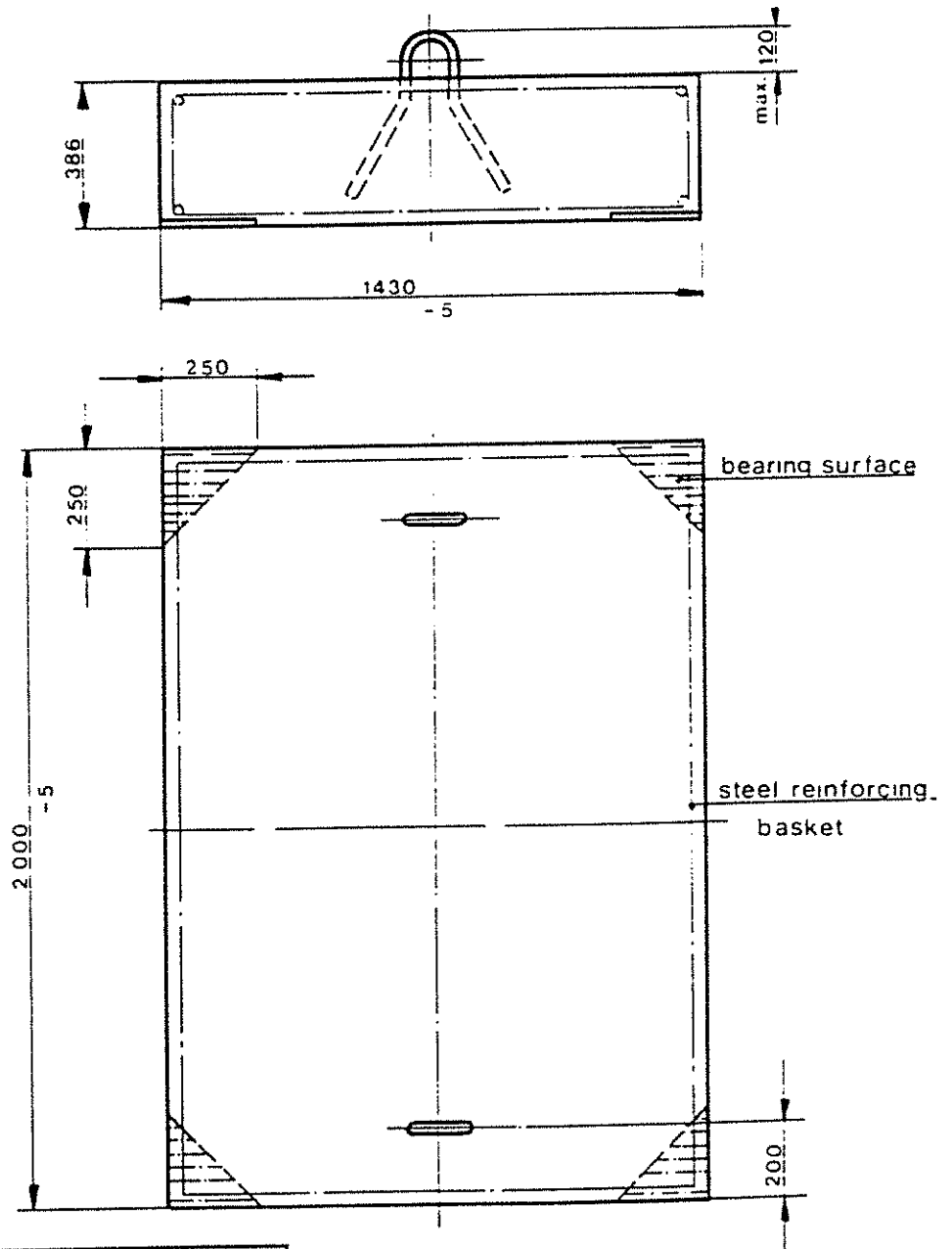

Weight		Volume
Nr.	t	m ³
1	2,65	1,10

Arrangement of the counterweights
see technical data

12.11.82 Sch. 1/1

Wolffkran 192SLWK 200 EC^{XIV} 10363

Örenter:

Hakenhöhe
Auslegerartenkounkthöhe
Gesamthöhe

Slewing part:

Height under hook
Height of jib pivot point
Total height

Partie tournante

Hauteur sous crochet
Haut. de l'axe du pied de flecne
Hauteur totale

A = 1.5 m
B = 3.7 m
C = 11.7 m

A = 1.5 m
B = 3.7 m
C = 11.7 m

A = 1.5 m
B = 3.7 m
C = 11.7 m

1 2 3 4 5 6

Hauteur tour
Hauteur sous
crochet
Hauteur totale
Hauteur sous
crochet
Hauteur totale



1	6.0		UT 20	UT 20	UT 20	UT 20	UT 20
2	10.5		UT 20	UT 20	UT 20	UT 20	UT 20
3	15.0		UT 20	UT 20	UT 20	UT 20	UT 20
4	19.5		UT 20	UT 20	UT 20	UT 20	UT 20
5	24.0		UT 20	UT 20	UT 20	UT 20	UT 20
6	28.5		UT 20	UT 20	UT 20	UT 20	UT 20
7	33.0		UT 20	UT 20	UT 20	TVA 20	TVA 20
8	37.5		UT 20	UT 20	TVA 20	TV 20	TV 20
9	42.0		UT 20	TVA 20	TV 20	TV 20	TV 20
10	46.5			TV 20	TV 20	TV 20	TV 20
11	51.0			TV 20	TV 20	TV 20	TV 20
12	55.5				TV 20	TV 20	TV 20
13	60.0				TV 20	TV 20	TV 20
14	64.5					TV 20	TV 20
15	69.0					TV 20	TV 20
16	73.5						TV 25
17	78.0						TV 25
18	82.5						

Die hier gezeigten Turmkombinationen stellen Empfehlungen für eine kostengünstige Kranaufstellung dar und können jederzeit verwendet werden. Jedes Turmelement gilt in der gezeigten Position auch als Turmbasisstück bei stationären Aufstellungen mit kleineren Hakenhöhen. Turmkombinationen mit größeren Hakenhöhen oder anderen Turmelementen sind möglich, müssen aber vor Aufstellung des Kranes von uns geprüft und schriftlich bestätigt werden.

The tower configurations are recommended for economic crane installations and may be used in any case. Each tower element in its indicated position may be used as a basic tower element for static cranes with its corresponding height under hook. Tower configurations not shown here, with greater heights u. h. or by means of other tower elements are possible but must be checked and confirmed by us in every individual case and before crane installation starts.

Les configurations de tour représentées constituent des recommandations pour une installation de grue favorable: elles peuvent être utilisées toujours. Chaque élément de tour fait également fonction de base de tour au cas d'installation stationnaire avec des hauteurs sous crochet moins importantes. Des combinaisons de tour avec des hauteurs plus importantes ou avec d'autres éléments de tour sont possibles, mais doivent être vérifiées et confirmées par avis écrit de nos services avant l'installation de la grue.

Wolffkran 192SLWK 200 EC^{XIV} 10364

Drehteil

Hakenhöhe
Auslegerankelpunkthöhe
Gesamthöhe

A = 1.5 m
B = 3.7 m
C = 11.7 m

Slewing part:

Height under hook
Height of jib pivot point
Total height

A = 1.5 m
B = 3.7 m
C = 11.7 m

Partie tournante

Hauteur sous crochet
Haut. de l'axe du pied de fleche
Hauteur totale





A = 1.5 m
B = 3.7 m
C = 11.7 m

1 2 3 4* 5 6

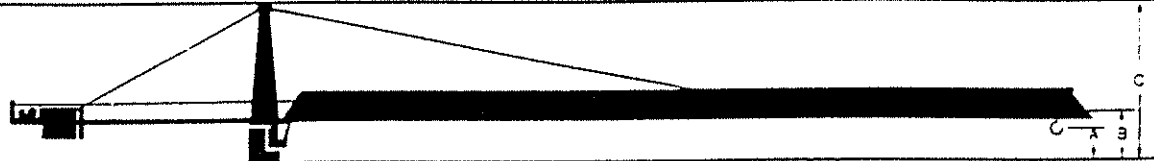
Arbeitshöhe
lower elements
à base de tour

Hakenhöhe (H)
Height of hook (H)
Hauteur sous crochet (H)

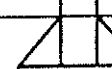

1	6.0		UT 20	UT 20	UT 20	UT 20	UT 20	
2	10.5		UT 20	UT 20	UT 20	UT 20	UT 20	
3	15.0		UT 20	UT 20	UT 20	UT 20	UT 20	
4	19.5		UT 20	UT 20	UT 20	UT 20	UT 20	
5	24.0		UT 20	UT 20	UT 20	UT 20	UT 20	
6	28.5		UT 20	UT 20	UT 20	UT 20	UT 20	
7	33.0		UT 20	UT 20	UT 20	TVA 20	TVA 20	
8	37.5		UT 20	UT 20	TVA 20	TV 20	TV 20	
9	42.0			TVA 20	TV 20	TV 20	TV 20	
10	46.5	UW 260.1		TV 20	TV 20	TV 20	TV 20	
11	51.0				TV 20	TV 20	TV 20	
12	55.5		UW 260.2		TV 20	TV 20	TV 20	
13	60.0					TV 20	TV 20	
14	64.5			UW 280.1			TV 20	
15	69.0				UW 260.3 UW 460		TVU 20	
16	73.5						TV 25	
17	78.0							
18	82.5	* bei 60 m Ausladung nur max. 60 m H.H. möglich					UW 280.2 UW 480	

Die hier gezeigten Turmkombinationen stellen Empfehlungen für eine kostengünstige Kранаufstellung dar und können jederzeit verwendet werden. Jedes Turmelement gilt in der gezeigten Position auch als Turmbasisstück bei stationären Aufstellungen mit kleineren Hakenhöhen. Turmkombinationen mit größeren Hakenhöhen oder anderen Turmelementen sind möglich, müssen aber vor Aufstellung des Kranes von uns geprüft und schriftlich bestätigt werden.

The tower configurations are recommended for economic crane installations and may be used in any case. Each tower element in its indicated position may be used as a basic tower element for static cranes with its corresponding height under hook. Tower configurations not shown here, with greater heights u. h. or by means of other tower elements are possible but must be checked and confirmed by us in every individual case and before crane installation starts.

Les configurations de tour représentées constituent des recommandations pour une installation de grue favorable: elles peuvent être utilisées toujours. Chaque élément de tour fait également fonction dans la position représentée, élément de base de tour au cas d'installation stationnaire avec des hauteurs sous crochet moins importantes. Des combinaisons de tour avec des hauteurs plus importantes ou avec d'autres éléments de tour sont possibles, mais doivent être vérifiées et confirmées par avis écrit de nos services avant l'installation de la grue.

Wolffkran WK 192 SL

WK 200 EC

Foundationloads

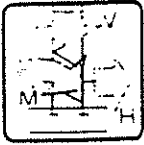

for cranes free standing without climbers on concrete foundation. Values given are for least favourable jib length. Other length of jib may result into lower foundation loads.

Always acting loads are:

Vertical forces of loadcase 2 and a moment of 918 kNm

free standing height under hook (m)	Crane in service (for loadcase 1 of DIN 1054) torquemoment: 228 kNm		
	M (kNm)*	H (kN)*	V (kN)*
15,0	2340	55	703
19,5	2616	56	723
24,0	2894	57	743
28,5	3172	59	768
33,0	3452	60	800
37,5	3738	62	831
42,0	4027	64	862
46,5	4320	65	893
51,0	4614	67	924
55,5	4911	69	955
60,0	5208	70	986
64,5	5505	72	1020
69,0	5802	74	1055
73,5	6102	76	1090
78,0	6404	77	1108

Crane out of service (for loadcase 2 of DIN 1054) torquemoment: 0 kNm		
M (kNm)*	H (kN)*	V (kN)*
1438**	31	227
1512**	32	245
1591**	33	263
1675**	34	281
2045	84	605
2450	91	533
2885	98	661
3351	106	689
3846	113	718
4369	120	746
4915	125	774
5479	131	804
6059	136	836
6657	142	868
7272	145	884

*New units for forces and moments to international law: 10 kNm \approx 1 t/m 10 kN \approx 1 tf

**Moments during crane erection









M = Moment

H = Horizontal force

V = Vertical load

Wolffkran 192 SL WK 200 EC^{XIV.10080 E}

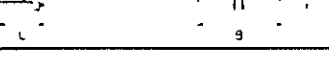
Colli-List

Pos	Quantity	Description	Colli	L (m)	W (m)	H (m)	Weight (kg)	Volume (m ³)
1	1	tower top, slinging system various bracing parts slewing frame, KDV, slewing drive lower tower top part		11.66	2.4	2.5	8610	69.96
Pos. 1 divided up		tower top, slinging system various bracing parts		7.79	2.0	2.2	2750	34.28
		slewing frame, KDV, slewing drive lower tower top part		5.03	2.4	2.5	5860	30.18
		slewing frame, KDV, slewing drive		1.69	2.4	2.44	2895	9.9
		lower tower top part		3.34	2.18	2.5	2965	18.2
2	1	tower top platform		1.4	0.95	1.22	140	1.62
3	1	driver's cabin suspension		1.22	1.76	0.29	230	0.63
4	1	driver's cabin		1.65	1.02	2.16	455	3.64
5	1	counterjib - head		9.25	1.84	0.58	1900	9.87
		7.27		2.44	0.71	1765	12.59	
6	1	platform with hoist unit		2.22	3.35	1.46	2800	10.86
7	1	jib part traversing drive		10.18	1.69	2.22	2095	38.19
8	1	jib part		10.22	1.63	2.08	1575	34.65
9	1	jib part traversing rope pulley		10.27	1.63	2.0	1680	33.48
10	1	jib part		10.26	1.63	1.93	1425	32.28
11	1	jib part		5.22	1.63	1.93	670	16.42
12	1	jib part		10.2	1.63	1.93	1055	32.09
13	1	jib part		5.32	1.63	1.94	845	16.82
14	1	rope swivel traverse traversing rope pulley		0.91	1.56	0.46	145	0.65
15	1	bracing parts		7.76	0.22	0.5	1020	0.85
16	1	trolley, complete		2.21	1.84	0.9	340	3.66
17	1	hook block		1.3	0.24	1.59	585	0.5
18	1	standard handrails		2.6	1.04	1.12	275	3.03
19	1	crate with small parts		1.6	0.9	0.8	370	1.15

12.11.02.10

Wolffkran 192 SL WK 200 EC XIV10137 E

Basic erection

For 10.5 m height under hook of the construction crane.

Erection single weights and heights under hook for the mobile crane.

For every additional tower element the necessary height under hook will be increased by 4.5 m.

Attention:

Upon basic erections with restricted erection weights, the main parts jib - tower top - counter jib can be further disassembled.

Further details colli list.

Suspension points see bracing plan

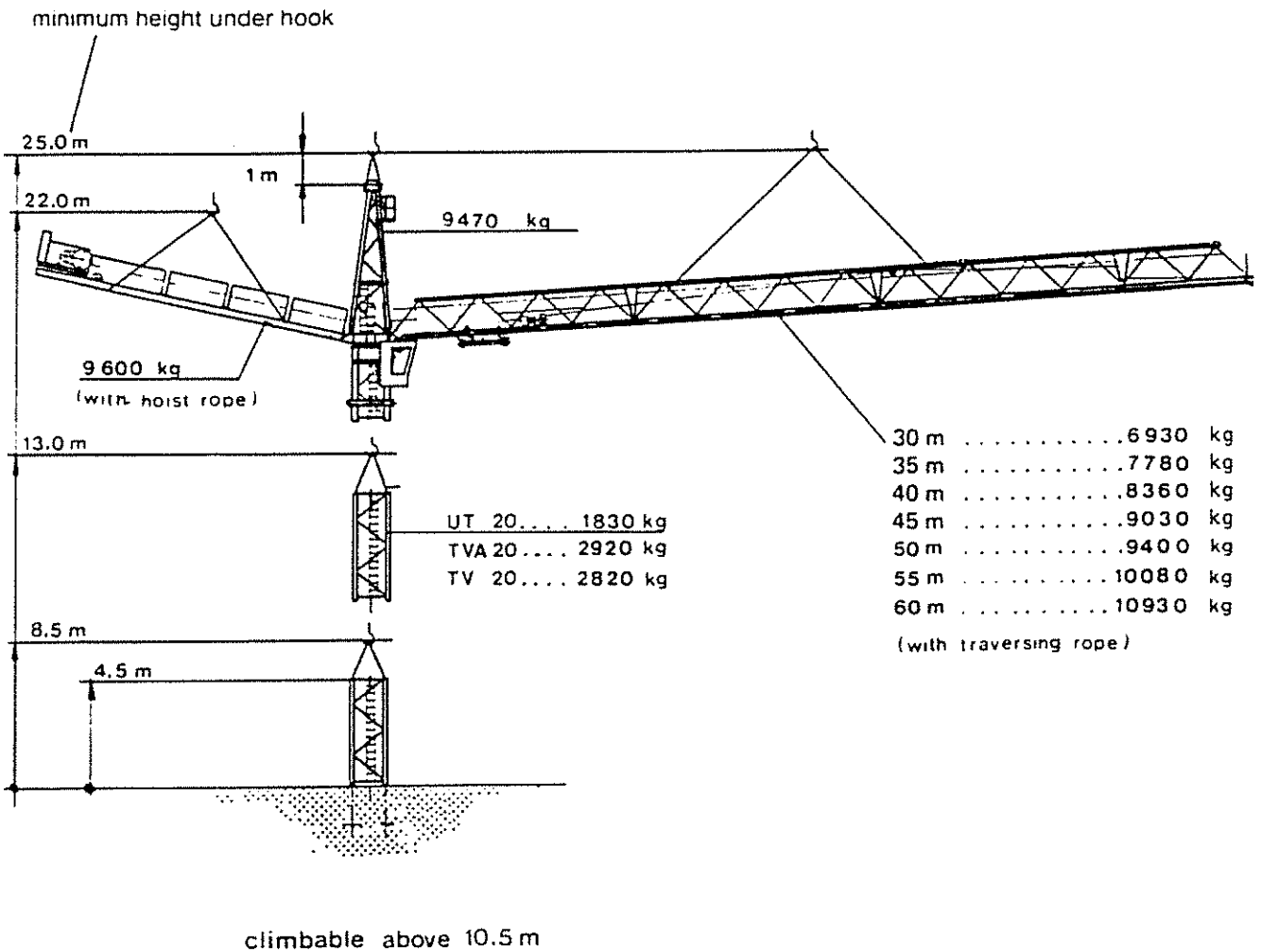

Wolffkran 192 SL WK 200 EC ^{XIV10130 E}

Basic erection

For 15.0 m height under hook of the construction crane.

Erection single weights and heights under hook for the mobile crane.

For every additional tower element the necessary height under hook will be increased by 4.5 m.

Attention:

Upon basic erections with restricted erection weights, the main parts jib - tower top - counter jib can be further disassembled.

Further details colli list.

Suspension points see bracing plan

minimum height under hook

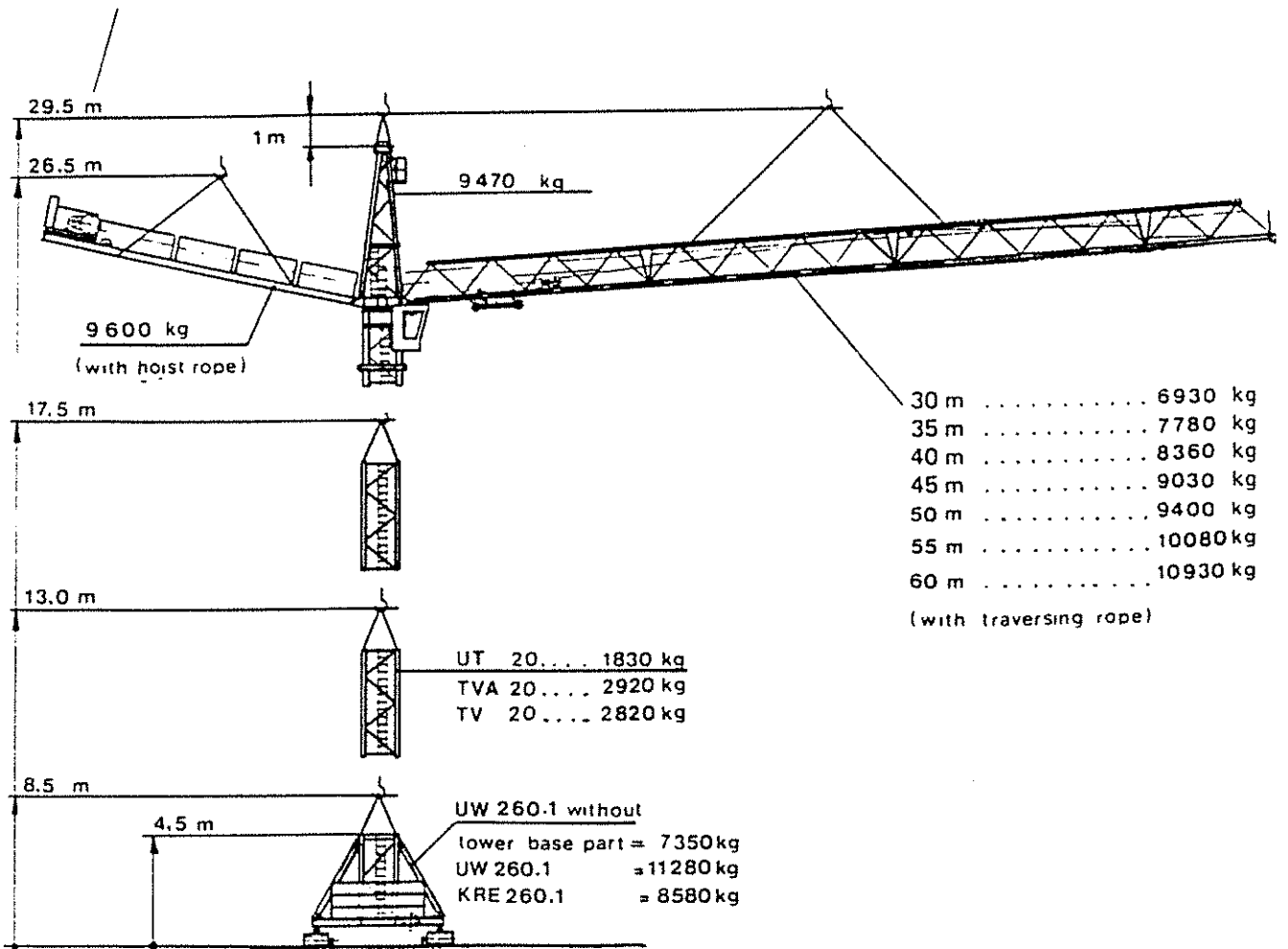

climbable above 15.0 m

12 11 82 Sch... Za.

Wolffkran 192 SL

962-4-000840 E

WK 200 EC

List of pins

Pos.	Connection	Pins		Spring plug		Split pin	
		Quantity	Dimension	Quantity	Dimension	Quantity	Dimension
1	jib joint, top	82.0 ft / 25 m					
		98.4 ft / 30 m	2	∅ 80x165	2	∅ 6/80	
		114.8 ft / 35 m	3	∅ 80x165	3	∅ 6/80	
		131.2 ft / 40 m	3	∅ 80x165	3	∅ 6/80	
		147.6 ft / 45 m	4	∅ 80x165	4	∅ 6/80	
		164.0 ft / 50 m	4	∅ 80x165	4	∅ 6/80	
		180.4 ft / 55 m	5	∅ 80x165	5	∅ 6/80	
	196.8 ft / 60 m	6	∅ 80x165	6	∅ 6/80		
	jib joint, bottom	82.0 ft / 25 m					
		98.4 ft / 30 m	6	∅ 70x143	8	∅ 6/80	
		114.8 ft / 35 m	8	∅ 70x143	8	∅ 6/80	
		131.2 ft / 40 m	8	∅ 70x143	8	∅ 6/80	
		147.6 ft / 45 m	10	∅ 70x143	10	∅ 6/80	
		164.0 ft / 50 m	10	∅ 70x143	10	∅ 6/80	
180.4 ft / 55 m		12	∅ 70x143	12	∅ 6/80		
196.8 ft / 60 m	14	∅ 70x143	14	∅ 6/80			
	link point jib	1	∅ 90x1806	2	wasner with bolt		
2							
3	bracing counter jib	4	∅ 70 x 180			4	∅ 10
		6	∅ 70 x 180			12	∅ 10
	link point counter jib	1	∅ 90x1806	2	wasner with bolt		
4	bracing troiley jib	1	∅ 70x240			2	∅ 10
		5	∅ 70x180			10	∅ 10
		1	∅ 70x260			2	∅ 10
		1	∅ 70x222	axle guard		40	x 10
5	lower tower top with sleeve	TV 20	4	∅ 70x290	8	∅ 10/--	
		UT 20	8	∅ 60x290	16	∅ 10/--	
		TVA 20	8	∅ 60x290	16	∅ 10/--	
		UV 20	8	∅ 60x290	16	∅ 10/--	

21.09.86 Schiedel

Wolffkran WK 200EC

962.4.000839 E

HT-bolt connections

Pos.	Connection	Bolts				Torque		
		Quantity	Dimensions	DIN	Quality grade	MoS2 Nm	Mo.S2 ft.lb	
1	ballrace bearing – slewing frame	44	M 24 x 140	931	12.9sg	960	695	
2	ballrace bearing – lower top part	44	M 24 x 140	931	12.9sg	960	695	
	extension sleeve – lower top part	44	∅ 45 x 11					
3	lower top – slewing frame	16	M 30 x 120 Mu	6914	10.9	erection 1650	1190	
4	counter jib – joint	12	M 24 x 100 Mu	6914	10.9	erection 800	580	
5	counter jib – m. platform	4	M 20 x 70 Mu	931	8.8	erection 330	240	
		2	M 30 x 80 Mu	931	8.8	1150	830	
6	hoist unit Hw 6372 or Hw 6453	– motor (Hw 6372)	8	M 16 x 70 Mu	931	8.8	170	120
		– motor (Hw 6453)	8	M 16 x 70 Mu	931	8.8	170	120
		– gear box	8	M 16 x 80 Mu M 16 x 160	931	8.8	170	120
		– brake	6	M 12 x 130	912	8.8	35	25
		– hope arom	8	M 20 x 70	6914	10.9	450	330
		– pedestal bearing	2	M 24 x 85 Mu	6914	10.9	450	330

Note:

- DIN 6914 – hexagon head cap bolt
- DIN 931 – hexagon head cap bolt
- DIN 912 – socket head cap bolt
- Mu – with nut
- sg – finally rolled

Attention: For the HT-bolt connections tempered plain washers DIN 6916 with chamfer outside must be used. Spring rings may not be used.

The bolts lubricated with MoS2 are installed.

The bearing surfaces must remain without grease.

22.04 83 Sdu. 14. 09 97. 1.2.1

Wolffkran 192 SL WK 200 EC XIV 10125 E

NG 1000 mm

Arrangement and quantity of the standard handrails (NG)

Slewing part WK 192 SL

NG 1000 mm

NG 1000 mm
NG 750 mm
NG 1000 mm

trolley jib

NG 2500 mm

NG 1000 mm
NG 1500 mm

driver's cabin

NG 2500 mm

NG 2500 mm
NG 2500 mm

NG 2500 mm

NG 2500 mm

counter jib

NG 2000mm

NG 2000mm

chain Ø 5x400mm

chain
Ø 5 x 600 mm

NG 2500 mm

NG 1500 mm
NG 2500 mm

NG 1500 mm

NG 2000mm
NG 2000mm

NGE 300

NG 1500

NGE 300

Standard handrails	
NG 750	= 1 x
NG 1000	= 5 x
NG 1500	= 4 x
NG 2000	= 4 x
NG 2500	= 8 x
NGE 300	= 2 x
chain Ø 5 x 400mm with 2 spring hooks	= 1 x
chain Ø 5 x 600mm with 2 spring hooks	= 1 x

12 11 B2 Seite 12

Wolffkran 192 SL

XIV 10180 E

lifting plan-jib

WK 200 EC

(A) (B) see XIV 10077E

the single parts of the jib are identified with No. 1-7 on the upper tension rod

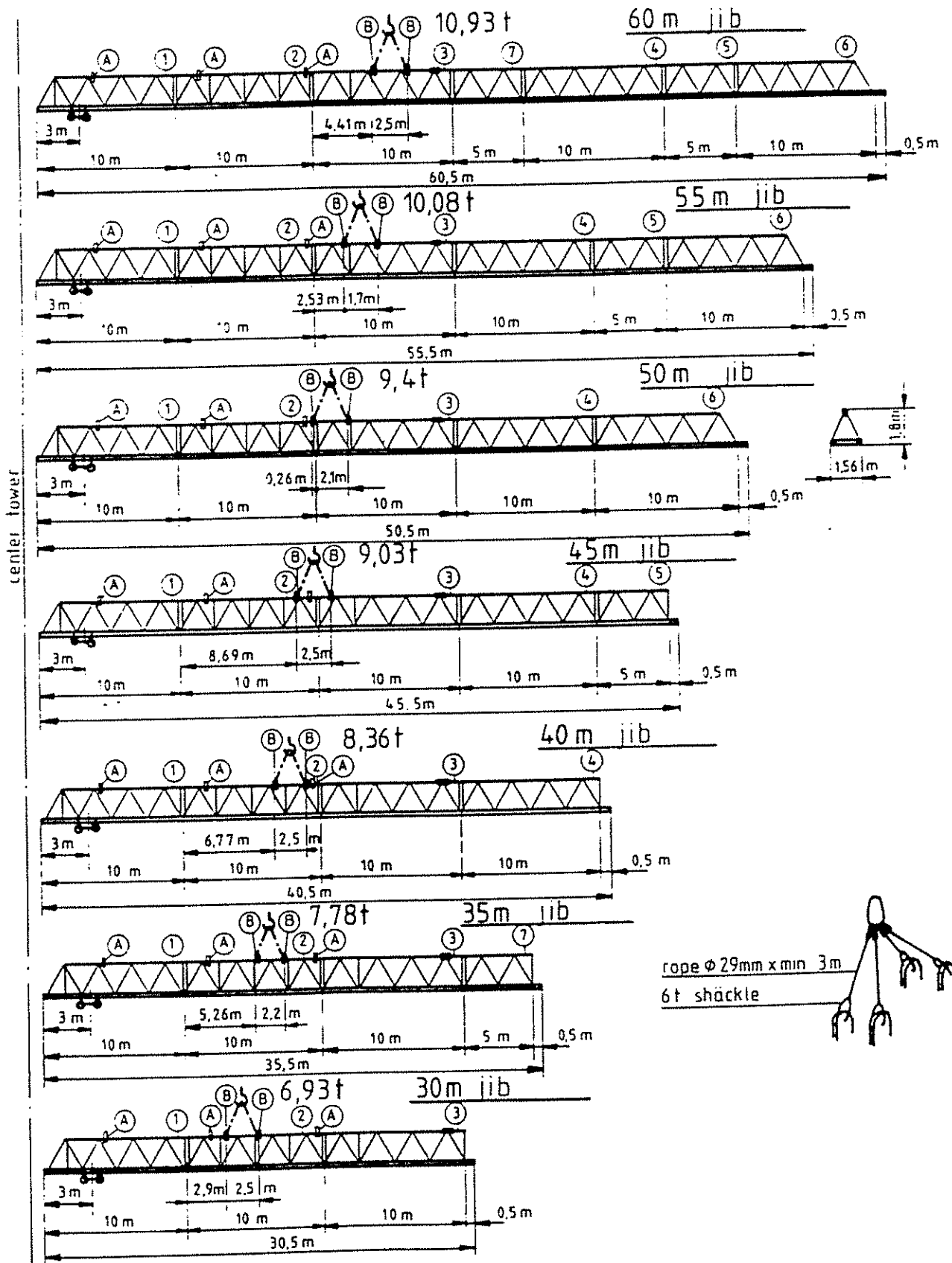

Wolffkran 192 SL WK 200 EC XIV 10077

(A) Halterung / Fixing XIV 9319

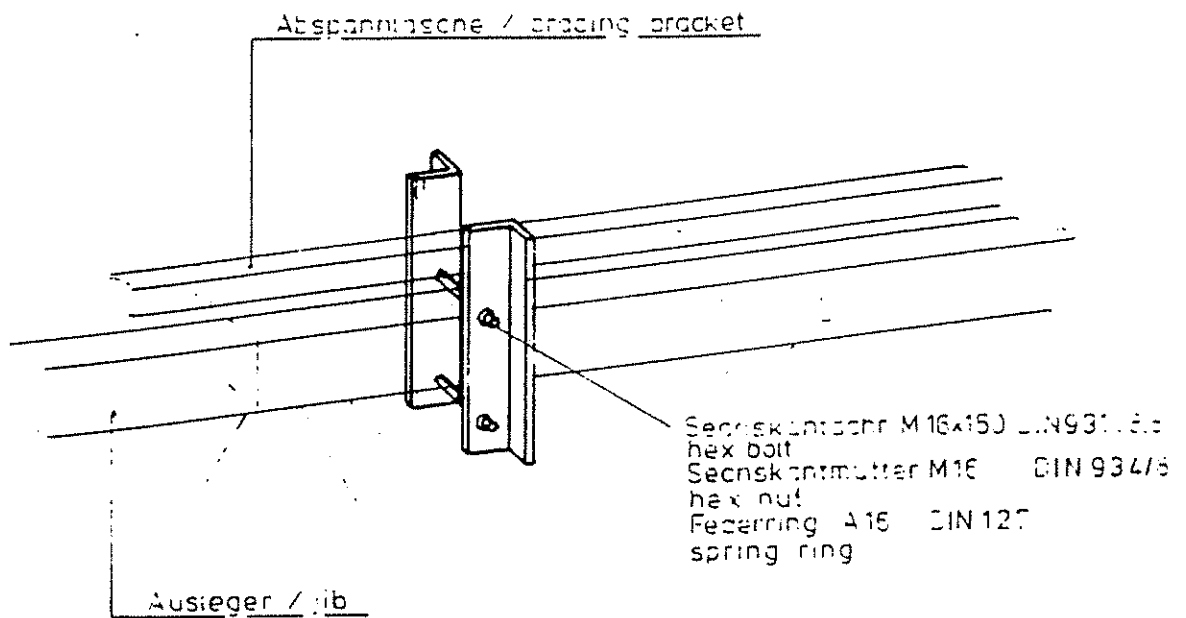

(B) Aufhängung / Suspension XIV 9319

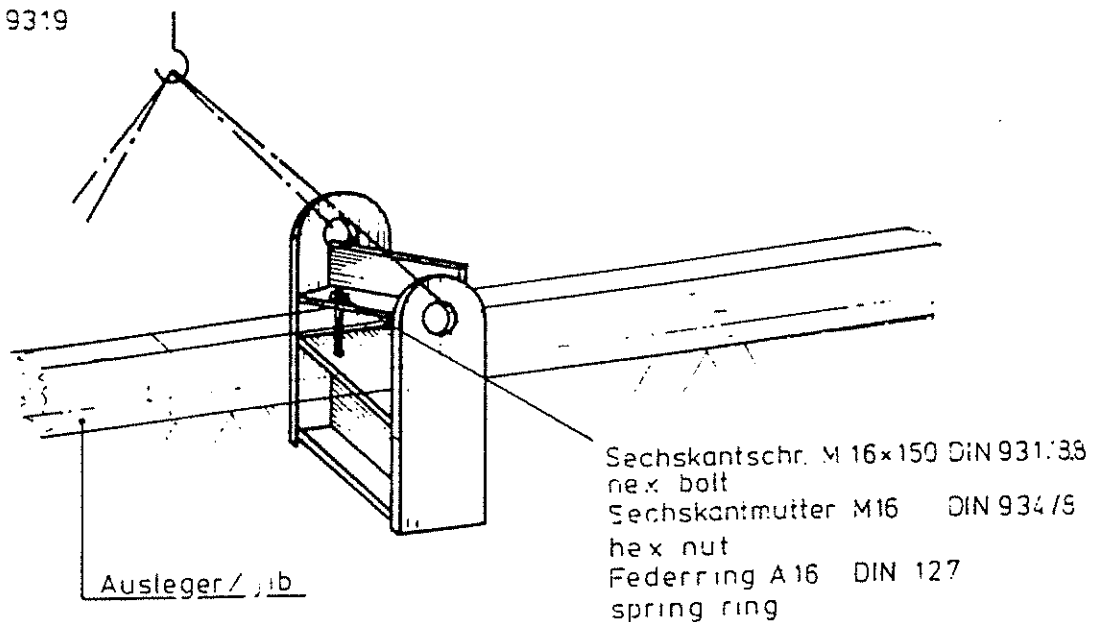

Wolffkran WK 192 SL

XIV 9524 E

WK 200 EC

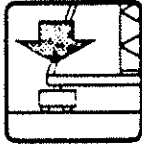

Centerballast and Cornerloads

DIN 15019

for travelling cranes without climber on undercarriages

Horizontal forces H and torquemoments to be taken from table 'Foundation loads'

UW 260.1. or for KRE

Height under hook (m)	30 m - jib				35 m - jib				40 m - jib				45 m - jib			
	Gauge (m)		Gauge (m)		Gauge (m)		Gauge (m)		Gauge (m)		Gauge (m)		Gauge (m)		Gauge (m)	
	6,0	5,0	6,0	5,0	6,0	5,0	6,0	5,0	6,0	5,0	6,0	5,0	6,0	5,0	6,0	5,0
	Center-ballast (t)		max. Corner-load (kN)*		Center-ballast (t)		max. Corner-load (kN)*		Center-ballast (t)		max. Corner-load (kN)*		Center-ballast (t)		max. Corner-load (kN)*	
15.0	30,0	47,5	432	480	27,5	45,0	434	481	22,5	42,5	423	476	22,5	40,0	431	479
19.5	32,5	52,5	453	506	30,0	50,0	454	509	27,5	45,0	449	497	23,0	42,5	452	500
24.0	35,0	55,0	474	528	32,5	52,5	476	530	30,0	47,5	470	519	27,5	47,5	474	528
28.5	37,5	60,0	496	556	35,0	57,5	498	558	32,5	52,5	493	547	30,0	50,0	496	551
33.0	40,0	62,5	519	580	37,5	60,0	521	581	35,0	55,0	516	571	32,5	55,0	520	580
37.5	45,0		548		40,0	62,5	545	606	37,5	60,0	540	601	35,0	57,5	544	605
42.0	47,5		576		45,0		578		40,0	62,5	568	629	40,0	62,5	577	638

Height under hook (m)	50 m - jib				55 m - jib				60 m - jib				m - jib			
	Gauge (m)		Gauge (m)		Gauge (m)		Gauge (m)		Gauge (m)		Gauge (m)		Gauge (m)		Gauge (m)	
	6,0	5,0	6,0	5,0	6,0	5,0	6,0	5,0	6,0	5,0	6,0	5,0	6,0	5,0	6,0	5,0
	Center-ballast (t)		max. Corner-load (kN)*		Center-ballast (t)		max. Corner-load (kN)*		Center-ballast (t)		max. Corner-load (kN)*		Center-ballast (t)		max. Corner-load (kN)*	
15.0	22,5	35,0	427	463	22,5	32,5	407	438	22,5	35,0	381	417				
19.5	22,5	37,5	447	485	22,5	32,5	423	454	22,5	35,0	396	432				
24.0	22,5	42,5	459	512	22,5	32,5	439	470	22,5	37,5	412	454				
28.5	25,0	45,0	482	535	22,5	35,0	456	493	25,0	37,5	435	471				
33.0	27,5	50,0	505	565	25,0	35,0	480	512	25,0	40,0	478	521				
37.5	32,5	52,5	535	590	25,0	42,5	499	548	27,5	42,5	545	587				
42.0	37,5	60,0	568	629	27,5	50,0	558	616	27,5	45,0	615	662				

* New units for forces and moments to international law: 10 kNm ≈ 1 t·m 10 kN ≈ 1 t

Wolffkran WK 192 SL

XIV 9525 E

WK 200 EC

Page 1

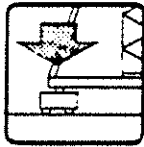

Centerballast and Cornerloads

DIN 15019

for travelling cranes without climber on undercarriages

Horizontal forces H and torquemoments to be taken from table "Foundation loads"

UW 280.2, UW 260.2, UW 480 or for KRE

Height under hook (m)	30 m - jib						25 m - jib						40 m - jib					
	Gauge (m)			Gauge (m)			Gauge (m)			Gauge (m)			Gauge (m)			Gauge (m)		
	8.0	6.0	5.0	8.0	6.0	5.0	8.0	6.0	5.0	8.0	6.0	5.0	8.0	6.0	5.0	8.0	6.0	5.0
	Centerballast (t)			max Cornerload (kN)*			Centerballast (t)			max Cornerload (kN)*			Centerballast (t)			max Cornerload (kN)*		
15.0	5.0	30.0	47.5	328	432	480	5.0	27.5	45.0	335	434	481	5.0	22.5	42.5	336	423	476
19.5	5.0	32.5	52.5	341	453	506	5.0	30.0	50.0	347	454	508	5.0	27.5	45.0	348	449	497
24.0	7.5	35.0	55.0	359	474	528	5.0	32.5	52.5	360	476	530	5.0	30.0	47.5	362	470	519
28.5	10.0	37.5	60.0	378	496	556	5.0	35.0	57.5	374	498	558	5.0	32.5	52.5	375	493	547
33.0	10.0	40.0	62.5	392	519	580	7.5	37.5	60.0	394	521	581	5.0	35.0	55.0	390	516	571
37.5	12.5	45.0	67.5	412	548	609	10.0	40.0	62.5	414	545	606	5.0	37.5	60.0	405	540	601
42.0	15.0	47.5	70.0	435	576	637	12.5	45.0	67.5	437	578	639	10.0	40.0	62.5	433	568	629
46.5	17.5	52.5	77.5	459	609	676	15.0	50.0	75.0	461	611	679	12.5	45.0	70.0	457	601	668
51.0	20.0	57.5	82.5	483	643	712	17.5	55.0	80.0	485	645	714	15.0	52.5	77.5	487	655	722
55.5	27.5			539			22.5			550			20.0			560		
60.0	32.5			614			30.0			630			27.5			641		
64.5	40.0			701			40.0			722			40.0			737		
69.0	52.5			801			52.5			822			52.5			838		
73.5	65.0			906			65.0			928			65.0			945		
78.0	80.0			1020			80.0			1042			80.0			1059		

Height under hook (m)	45 m - jib						50 m - jib						55 m - jib					
	Gauge (m)			Gauge (m)			Gauge (m)			Gauge (m)			Gauge (m)			Gauge (m)		
	8.0	6.0	5.0	8.0	6.0	5.0	8.0	6.0	5.0	8.0	6.0	5.0	8.0	6.0	5.0	8.0	6.0	5.0
	Centerballast (t)			max Cornerload (kN)*			Centerballast (t)			max Cornerload (kN)*			Centerballast (t)			max Cornerload (kN)*		
15.0	5.0	22.5	40.0	344	431	479	5.0	22.5	35.0	341	427	463	5.0	22.5	32.5	329	407	438
19.5	5.0	25.0	42.5	356	452	500	5.0	22.5	37.5	354	442	485	5.0	22.5	32.5	341	423	454
24.0	5.0	27.5	47.5	369	474	528	5.0	22.5	42.5	367	459	512	5.0	22.5	32.5	354	439	470
28.5	5.0	30.0	50.0	383	496	551	5.0	25.0	45.0	381	482	535	5.0	22.5	35.0	368	456	493
33.0	5.0	32.5	55.0	398	520	580	5.0	27.5	50.0	395	505	565	5.0	25.0	35.0	383	480	512
37.5	5.0	35.0	57.5	413	544	605	5.0	32.5	52.5	411	535	590	5.0	25.0	42.5	398	499	548
42.0	7.5	40.0	62.5	436	577	638	5.0	37.5	60.0	429	568	629	5.0	27.5	50.0	432	558	616
46.5	10.0	45.0	70.0	460	610	678	7.5	42.5	65.0	461	620	680	5.0	32.5	55.0	487	641	699
51.0	15.0	50.0	77.5	509	677	749	10.0	47.5	72.5	526	707	773	12.5	45.0		562	743	
55.5	17.5			577			20.0			609			22.5			646		
50.0	27.5			664			32.5			700			35.0			737		
64.5	40.0			761			45.0			798			47.5			835		
69.0	55.0			866			57.5			899			60.0			937		
73.5	67.5			973			72.5			1011			75.0			1049		
78.0	82.5			1088			87.5			1127			90.0			1165		

* New units for forces and moments to international law: 10 kNm ≈ 1 tfm

10 kN ≈ 1 tf

La Val

Wolffkran WK 192 SL

XIV 9526 E

WK 200 EC Page 1



Centerballast and Cornerloads

DIN 15019

for travelling cranes without climber on undercarriages

Horizontal forces H and torquemoments to be taken from table "Foundation loads"

UW 460; UW 260.3; UW 280.1 or for KRE

Height under hook (m)	30 m - jib						35 m - jib						40 m - jib					
	Gauge (m)			Gauge (m)			Gauge (m)			Gauge (m)			Gauge (m)			Gauge (m)		
	8.0	7.0	6.0	8.0	7.0	6.0	8.0	7.0	6.0	8.0	7.0	6.0	8.0	7.0	6.0	8.0	7.0	6.0
	Centerballast (t)			max. Cornerload (kN)*			Centerballast (t)			max. Cornerload (kN)*			Centerballast (t)			max. Cornerload (kN)*		
15.0	5.0	15.0	30.0	328	354	432	5.0	12.5	27.5	335	355	434	5.0	10.0	22.5	336	351	423
19.5	5.0	15.0	32.5	341	367	453	5.0	12.5	30.0	347	368	454	5.0	10.0	27.5	348	364	449
24.0	7.5	17.5	35.0	359	385	474	5.0	15.0	32.5	360	387	476	5.0	12.5	30.0	362	383	470
28.5	10.0	20.0	37.5	378	404	496	5.0	17.5	35.0	374	406	498	5.0	12.5	32.5	375	397	493
33.0	10.0	22.5	40.0	392	424	519	7.5	20.0	37.5	394	426	521	5.0	15.0	35.0	390	417	516
37.5	12.5	25.0	45.0	412	445	548	10.0	20.0	40.0	414	441	545	5.0	17.5	37.5	405	437	540
42.0	15.0	27.5	47.5	435	468	576	12.5	25.0	45.0	437	470	578	10.0	20.0	40.0	433	461	568
46.5	17.5	30.0	52.5	459	492	609	15.0	27.5	50.0	461	494	611	12.5	25.0	45.0	457	490	601
51.0	20.0	35.0	57.5	483	523	643	17.5	32.5	55.0	485	525	645	15.0	30.0	52.5	487	525	655
55.5	27.5	40.0	62.5	539	572	713	22.5	37.5	60.0	550	587	733	20.0	35.0	57.5	560	597	746
60.0	32.5	47.5	70.0	614	653	813	30.0	42.5	67.5	630	664	835	27.5	42.5	65.0	641	679	849
64.5		80.0			927			80.0			953			80.0				973
69.0																		
73.5																		

Height under hook (m)	45 m - jib						50 m - jib						55 m - jib					
	Gauge (m)			Gauge (m)			Gauge (m)			Gauge (m)			Gauge (m)			Gauge (m)		
	8.0	7.0	6.0	8.0	7.0	6.0	8.0	7.0	6.0	8.0	7.0	6.0	8.0	7.0	6.0	8.0	7.0	6.0
	Centerballast (t)			max. Cornerload (kN)*			Centerballast (t)			max. Cornerload (kN)*			Centerballast (t)			max. Cornerload (kN)*		
15.0	5.0	10.0	22.5	344	359	431	5.0	10.0	22.5	341	357	427	5.0	10.0	22.5	329	344	407
19.5	5.0	10.0	25.0	356	372	452	5.0	10.0	22.5	354	369	442	5.0	10.0	22.5	341	357	423
24.0	5.0	10.0	27.5	369	385	474	5.0	10.0	22.5	367	383	459	5.0	10.0	22.5	354	370	439
28.5	5.0	12.5	30.0	383	405	496	5.0	10.0	25.0	381	397	482	5.0	12.5	22.5	368	390	456
33.0	5.0	15.0	32.5	398	425	520	5.0	12.5	27.5	395	417	505	5.0	12.5	25.0	383	404	480
37.5	5.0	15.0	35.0	413	440	544	5.0	12.5	32.5	411	432	535	5.0	12.5	25.0	398	419	499
42.0	7.5	20.0	40.0	436	469	577	5.0	17.5	37.5	429	462	568	5.0	12.5	27.5	432	453	558
46.5	10.0	22.5	45.0	460	493	610	7.5	20.0	42.5	461	493	620	5.0	12.5	32.5	487	509	641
51.0	15.0	27.5	50.0	509	541	677	10.0	25.0	47.5	526	562	707	12.5	25.0	45.0	562	594	743
55.5	17.5	32.5	55.0	577	614	770	20.0	35.0	55.0	609	646	806	22.5	37.5	60.0	646	683	856
60.0	27.5	42.5	67.5	664	702	882	32.5	47.5	72.5	700	739	927	35.0	50.0	75.0	737	776	974
64.5		85.0			1011			90.0			1057			95.0				1108
69.0																		
73.5																		

* New units for forces and moments to international law: 10 kNm ≈ 1 tfm 10 kN ≈ 1 tf

K4 Kt. 19. 80

Wolffkran WK 192 SL WK 200 EC Page 2



Centerballast and Cornerloads DIN 15019

for travelling cranes without climber on undercarriages
 Horizontal forces H and torquemoments to be taken from table "Foundation loads"
 UW 460; UW 260.3; UW 280.1 or for KRE

Height under hook (m)	60 m - jib						m - jib			m - jib		
	Gauge (m)			Gauge (m)			Gauge (m)	Gauge (m)		Gauge (m)	Gauge (m)	
	8,0	7,0	6,0	8,0	7,0	6,0		Centerballast (t)	max		Cornerload (kN)*	Centerballast (t)
15.0	5.0	10.0	22.5	311	326	381						
19.5	5.0	10.0	22.5	324	339	396						
24.0	5.0	10.0	22.5	336	352	412						
28.5	5.0	12.5	25.0	350	371	435						
33.0	5.0	12.5	25.0	375	397	478						
37.5	7.5	12.5	27.5	427	443	545						
42.0	7.5	12.5	27.5	479	496	615						
46.5	7.5	20.0	37.5	536	567	707						
51.0	17.5	30.0	52.5	616	648	815						
55.5	27.5	42.5	67.5	700	737	927						
60.0	40.0		82.5	792		1046						
64.5												
69.0												
73.5												

Height under hook (m)	m - jib		m - jib		m - jib	
	Gauge (m)		Gauge (m)		Gauge (m)	
	Centerballast (t)	max Cornerload (kN)*	Centerballast (t)	max Cornerload (kN)*	Centerballast (t)	max Cornerload (kN)*

* New units for forces and moments to international law: 10 kNm ≈ 1 t·m 10 kN ≈ 1 t

K&K 12.02.04.20

Wolffkran WK 200EC

XIV10361E

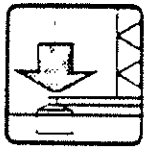
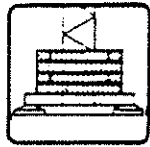

Centerballast and Cornerloads

DIN 15019

for stationary crane without climber on crossframe

Horizontal forces H and torquemoments to be taken from table Foundation loads

KR 1000-8, KR 1000-6

Height under hook (m)	30 m - jib				35 m - jib				40 m - jib				45 m - jib			
	Centerballast		max Corner-load		Centerballast		max Corner-load		Centerballast		max Corner-load		Centerballast		max Corner-load	
	8.0	6.0	8.0	6.0	8.0	6.0	8.0	6.0	8.0	6.0	8.0	6.0	8.0	6.0	8.0	6.0
15.0	2.5	30.0	316	417	2.5	27.5	322	418	2.5	22.5	324	408	2.5	22.5	331	416
19.5	2.5	32.5	328	438	2.5	30.0	335	439	2.5	27.5	336	434	2.5	25.0	344	437
24.0	2.5	35.0	341	459	2.5	32.5	348	460	2.5	30.0	349	455	2.5	27.5	357	459
28.5	5.0	37.5	360	481	2.5	35.0	362	483	2.5	32.5	363	478	2.5	30.0	371	481
33.0	5.0	40.0	376	504	2.5	37.5	378	506	2.5	35.0	379	501	2.5	32.5	387	505
37.5	5.0	42.5	393	530	2.5	40.0	395	532	2.5	35.0	397	522	2.5	35.0	405	531
42.0	10.0	45.0	422	557	5.0	42.5	418	559	2.5	40.0	414	554	2.5	37.5	423	558
46.5	12.5		445		10.0		447		5.0		438		5.0		446	
51.0	15.0		470		12.5		472		10.0		474		7.5		490	
55.0	20.0		521		17.5		536		15.0		546		12.5		563	
60.0	27.5		601		22.5		612		20.0		623		22.5		650	
64.5	35.0		687		32.5		704		32.5		719		35.0		747	
69.0	45.0		782		47.5		808		47.5		824		47.5		848	
73.5	60.0		891		60.0		913		60.0		930		62.5		958	
78.0	75.0		1005		75.0		1027		75.5		1044		77.5		1074	

Height under hook (m)	50 m - jib				55 m - jib				60 m - jib				m - jib			
	Centerballast		max Corner-load		Centerballast		max Corner-load		Centerballast		max Corner-load		Centerballast		max Corner-load	
	8.0	6.0	8.0	6.0	8.0	6.0	8.0	6.0	8.0	6.0	8.0	6.0	8.0	6.0	8.0	6.0
15.0	2.5	22.5	329	412	2.5	22.5	316	392	2.5	22.5	299	366				
19.5	2.5	22.5	341	427	2.5	22.5	329	408	2.5	22.5	311	381				
24.0	2.5	22.5	355	444	2.5	22.5	342	424	2.5	22.5	324	397				
28.5	2.5	25.0	368	466	2.5	22.5	356	441	2.5	25.0	338	419				
33.0	2.5	27.5	385	490	2.5	22.5	372	459	2.5	25.0	365	463				
37.5	2.5	30.0	402	517	2.5	25.0	390	486	2.5	25.0	413	527				
42.0	2.5	35.0	420	549	2.5	27.5	423	545	2.5	25.0	465	597				
46.5	2.5		447		2.5		478		2.5		522					
51.0	5.0		512		7.5		548		10.0		598					
55.5	15.0		595		17.5		632		22.5		686					
60.0	25.0		682		27.5		719		32.5		774					
64.5	37.5		779		40.0		817		45.0		872					
69.0	52.5		885		55.0		923		60.0		979					
73.5	65.0		992		70.0		1035		75.0		1091					
78.0	82.5		1112		85.0		1151		90.0		1207					

* New units for forces and moments to international law: 10 kNm = 1 tfm 10 kN = 1 tf

Wolffkran WK 192 SL WK 200 EC

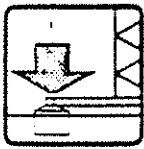
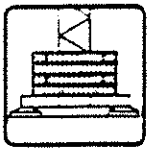

Centerballast and Cornerloads DIN 15 019

for stationary crane without climber on crossframe

Horizontal forces H and torquemoments to be taken from table "Foundation loads"

KR 800-6

Height under hook (m)	30,0 m - jib				35,0 m - jib				40,0 m - jib				45,0 m - jib			
	Cornerdistance (m)		Cornerdistance (m)		Cornerdistance (m)		Cornerdistance (m)		Cornerdistance (m)		Cornerdistance (m)		Cornerdistance (m)		Cornerdistance (m)	
	8,0	6,0	8,0	6,0	8,0	6,0	8,0	6,0	8,0	6,0	8,0	6,0	8,0	6,0	8,0	6,0
	Center-ballast (t)		max. Corner-load (kN)*		Center-ballast (t)		max. Corner-load (kN)*		Center-ballast (t)		max. Corner-load (kN)*		Center-ballast (t)		max. Corner-load (kN)*	
15,0	30,0		417		27,5		418		22,5		408		22,5		416	
19,5	32,5		438		30,0		439		27,5		434		25,0		437	
24,0	35,0		459		32,5		460		30,0		455		27,5		459	
28,5	37,5		481		35,0		483		32,5		478		30,0		481	
33,0																
37,5																
42,0																

Height under hook (m)	50,0 m - jib				55,0 m - jib				60,0 m - jib				m - jib			
	Cornerdistance (m)		Cornerdistance (m)		Cornerdistance (m)		Cornerdistance (m)		Cornerdistance (m)		Cornerdistance (m)		Cornerdistance (m)		Cornerdistance (m)	
	8,0	6,0	8,0	6,0	8,0	6,0	8,0	6,0	8,0	6,0	8,0	6,0	8,0	6,0	8,0	6,0
	Center-ballast (t)		max. Corner-load (kN)*		Center-ballast (t)		max. Corner-load (kN)*		Center-ballast (t)		max. Corner-load (kN)*		Center-ballast (t)		max. Corner-load (kN)*	
15,0	22,5		412		22,5		392		22,5		366					
19,5	22,5		427		22,5		408		22,5		381					
24,0	22,5		444		22,5		424		22,5		397					
28,5	25,0		466		22,5		441		25,0		419					
33,0	27,5		490		22,5		459		25,0		463					
37,5					25,0		486									
42,0																

* New units for forces and moments to international law: 10 kNm ≈ 1 t/m

10 kN ≈ 1 t

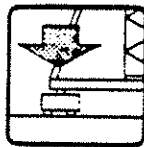

Centerballast and Cornerloads DIN 15019

for stationary crane without climber on crossframe

Horizontal forces H and torquemoments to be taken from table "Foundation loads"

UW 280.2, UW 260.2, UW 480 or for KRE

Height under hook (m)	60 m – jib						m – jib		m – jib	
	Cornerdistance (m)			Cornerdistance (m)			Cornerdistance (m)	Cornerdistance (m)	Cornerdistance (m)	Cornerdistance (m)
	8.0	6.0	5.0	8.0	6.0	5.0				
	Centerballast (t)			max. Cornerload (kN)*			Centerballast (t)	max. Cornerload (kN)*	Centerballast (t)	max. Cornerload (kN)*
15.0	5.0	22.5	35.0	311	381	417				
19.5	5.0	22.5	35.0	324	396	432				
24.0	5.0	22.5	37.5	336	412	454				
28.5	5.0	25.0	37.5	350	435	471				
33.0	5.0	25.0	40.0	375	478	521				
37.5	7.5	27.5	42.5	427	545	587				
42.0	7.5	27.5	45.0	479	615	662				
46.5	7.5	37.5	60.0	536	707	766				
51.0	17.5	52.5		616	815					
55.5	27.5			700						
60.0	40.0			792						
64.5	52.5			890						
69.0	65.0			993						
73.5	80.0			1105						
78.0	95.0			1222						

Height under hook (m)	m – jib		m – jib		m – jib	
	Cornerdistance (m)	Cornerdistance (m)	Cornerdistance (m)	Cornerdistance (m)	Cornerdistance (m)	Cornerdistance (m)
	Centerballast (t)	max. Cornerload (kN)*	Centerballast (t)	max. Cornerload (kN)*	Centerballast (t)	max. Cornerload (kN)*

* New units for forces and moments to international law: 10 kNm ≈ 1 tfm 10 kN ≈ 1 tf

kiv 10.04.90

Wolffkran WK 200EC

XIV10361E

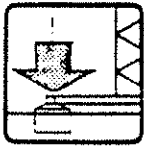
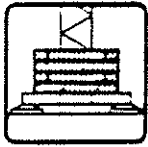

Centerballast and Cornerloads

DIN 15019

for stationary crane without climber on crossframe

Horizontal forces H and torquemoments to be taken from table "Foundation loads"

KR 1000-8, KR 1000-6

Height under hook (m)	30 m - jib				35 m - jib				40 m - jib				45 m - jib			
	Cornerdistance (m)		Cornerdistance (m)		Cornerdistance (m)		Cornerdistance (m)		Cornerdistance (m)		Cornerdistance (m)		Cornerdistance (m)		Cornerdistance (m)	
	8,0	6,0	8,0	6,0	8,0	6,0	8,0	6,0	8,0	6,0	8,0	6,0	8,0	6,0	8,0	6,0
	Centerballast (t)		max. Cornerload (kN)*		Centerballast (t)		max. Cornerload (kN)*		Centerballast (t)		max. Cornerload (kN)*		Centerballast (t)		max. Cornerload (kN)*	
15.0	2,5	30,0	316	417	2,5	27,5	322	418	2,5	22,5	324	408	2,5	22,5	331	416
19.5	2,5	32,5	328	438	2,5	30,0	335	439	2,5	27,5	336	434	2,5	25,0	344	437
24.0	2,5	35,0	341	459	2,5	32,5	348	460	2,5	30,0	349	455	2,5	27,5	357	459
28.5	5,0	37,5	360	481	2,5	35,0	362	483	2,5	32,5	363	478	2,5	30,0	371	481
33.0	5,0	40,0	376	504	2,5	37,5	378	506	2,5	35,0	379	501	2,5	32,5	387	505
37.5	5,0	42,5	393	530	2,5	40,0	395	532	2,5	35,0	397	522	2,5	35,0	405	531
42.0	10,0	45,0	422	557	5,0	42,5	418	559	2,5	40,0	414	554	2,5	37,5	423	558
46.5	12,5		445		10,0		447		5,0		438		5,0		446	
51.0	15,0		470		12,5		472		10,0		474		7,5		490	
55.0	20,0		521		17,5		536		15,0		546		12,5		563	
60.0	27,5		601		22,5		612		20,0		623		22,5		650	
64.5	35,0		687		32,5		704		32,5		719		35,0		747	
69.0	45,0		782		47,5		808		47,5		824		47,5		848	
73.5	60,0		891		60,0		913		60,0		930		62,5		958	
78.0	75,0		1005		75,0		1027		75,5		1044		77,5		1074	

Height under hook (m)	50 m - jib				55 m - jib				60 m - jib				m - jib			
	Cornerdistance (m)		Cornerdistance (m)		Cornerdistance (m)		Cornerdistance (m)		Cornerdistance (m)		Cornerdistance (m)		Cornerdistance (m)		Cornerdistance (m)	
	8,0	6,0	8,0	6,0	8,0	6,0	8,0	6,0	8,0	6,0	8,0	6,0	8,0	6,0	8,0	6,0
	Centerballast (t)		max. Cornerload (kN)*		Centerballast (t)		max. Cornerload (kN)*		Centerballast (t)		max. Cornerload (kN)*		Centerballast (t)		max. Cornerload (kN)*	
15.0	2,5	22,5	329	412	2,5	22,5	316	392	2,5	22,5	299	366				
19.5	2,5	22,5	341	427	2,5	22,5	329	408	2,5	22,5	311	381				
24.0	2,5	22,5	355	444	2,5	22,5	342	424	2,5	22,5	324	397				
28.5	2,5	25,0	368	466	2,5	22,5	356	441	2,5	25,0	338	419				
33.0	2,5	27,5	385	490	2,5	22,5	372	459	2,5	25,0	365	463				
37.5	2,5	30,0	402	517	2,5	25,0	390	486	2,5	25,0	413	527				
42.0	2,5	35,0	420	549	2,5	27,5	423	545	2,5	25,0	465	597				
46.5	2,5		447		2,5		478		2,5		522					
51.0	5,0		512		7,5		548		10,0		598					
55.5	15,0		595		17,5		632		22,5		686					
60.0	25,0		682		27,5		719		32,5		774					
64.5	37,5		779		40,0		817		45,0		872					
69.0	52,5		885		55,0		923		60,0		979					
73.5	65,0		992		70,0		1035		75,0		1091					
78.0	82,5		1112		85,0		1151		90,0		1207					

* New units for forces and moments to international law: 10 kNm ≈ 1 t·m 10 kN ≈ 1 t

Wolffkran WK 200 EC

XIV 9524 E

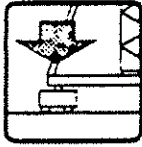

Centerballast and Cornerloads

DIN 15019

for travelling cranes without climber on undercarriages

Horizontal forces H and torquemoments to be taken from table 'Foundation loads'

UW 260.1. or for KRE

Height under hook (m)	30 m - jib				35 m - jib				40 m - jib				45 m - jib			
	Gauge (m)		Gauge (m)		Gauge (m)		Gauge (m)		Gauge (m)		Gauge (m)		Gauge (m)		Gauge (m)	
	6.0	5.0	6.0	5.0	6.0	5.0	6.0	5.0	6.0	5.0	6.0	5.0	6.0	5.0	6.0	5.0
	Center-ballast (t)		max. Corner-load (kN)*		Center-ballast (t)		max. Corner-load (kN)*		Center-ballast (t)		max. Corner-load (kN)*		Center-ballast (t)		max. Corner-load (kN)*	
15.0	30.0	47.5	432	480	27.5	45.0	434	481	22.5	42.5	423	476	22.5	40.0	431	479
19.5	32.5	52.5	453	506	30.0	50.0	454	509	27.5	45.0	449	497	23.0	42.5	452	500
24.0	35.0	55.0	474	528	32.5	52.5	476	530	30.0	47.5	470	519	27.5	47.5	474	528
28.5	37.5	60.0	496	556	35.0	57.5	498	558	32.5	52.5	493	547	30.0	50.0	496	551
33.0	40.0	62.5	519	580	37.5	60.0	521	581	35.0	55.0	516	571	32.5	55.0	520	580
37.5	45.0		548		40.0	62.5	545	606	37.5	60.0	540	601	35.0	57.5	544	605
42.0	47.5		576		45.0		578		40.0	62.5	568	629	40.0	62.5	577	638

Height under hook (m)	50 m - jib				55 m - jib				60 m - jib				m - jib			
	Gauge (m)		Gauge (m)		Gauge (m)		Gauge (m)		Gauge (m)		Gauge (m)		Gauge (m)		Gauge (m)	
	6.0	5.0	6.0	5.0	6.0	5.0	6.0	5.0	6.0	5.0	6.0	5.0	6.0	5.0	6.0	5.0
	Center-ballast (t)		max. Corner-load (kN)*		Center-ballast (t)		max. Corner-load (kN)*		Center-ballast (t)		max. Corner-load (kN)*		Center-ballast (t)		max. Corner-load (kN)*	
15.0	22.5	35.0	427	463	22.5	32.5	407	438	22.5	35.0	381	417				
19.5	22.5	37.5	447	485	22.5	32.5	423	454	22.5	35.0	396	432				
24.0	22.5	42.5	459	512	22.5	32.5	439	470	22.5	37.5	412	454				
28.5	25.0	45.0	482	535	22.5	35.0	456	493	25.0	37.5	435	471				
33.0	27.5	50.0	505	565	25.0	35.0	480	512	25.0	40.0	478	521				
37.5	32.5	52.5	535	590	25.0	42.5	499	548	27.5	42.5	545	587				
42.0	37.5	60.0	568	629	27.5	50.0	558	616	27.5	45.0	615	662				

* New units for forces and moments to international law: 10 kNm ≈ 1 tfm

10 kN ≈ 1 tf

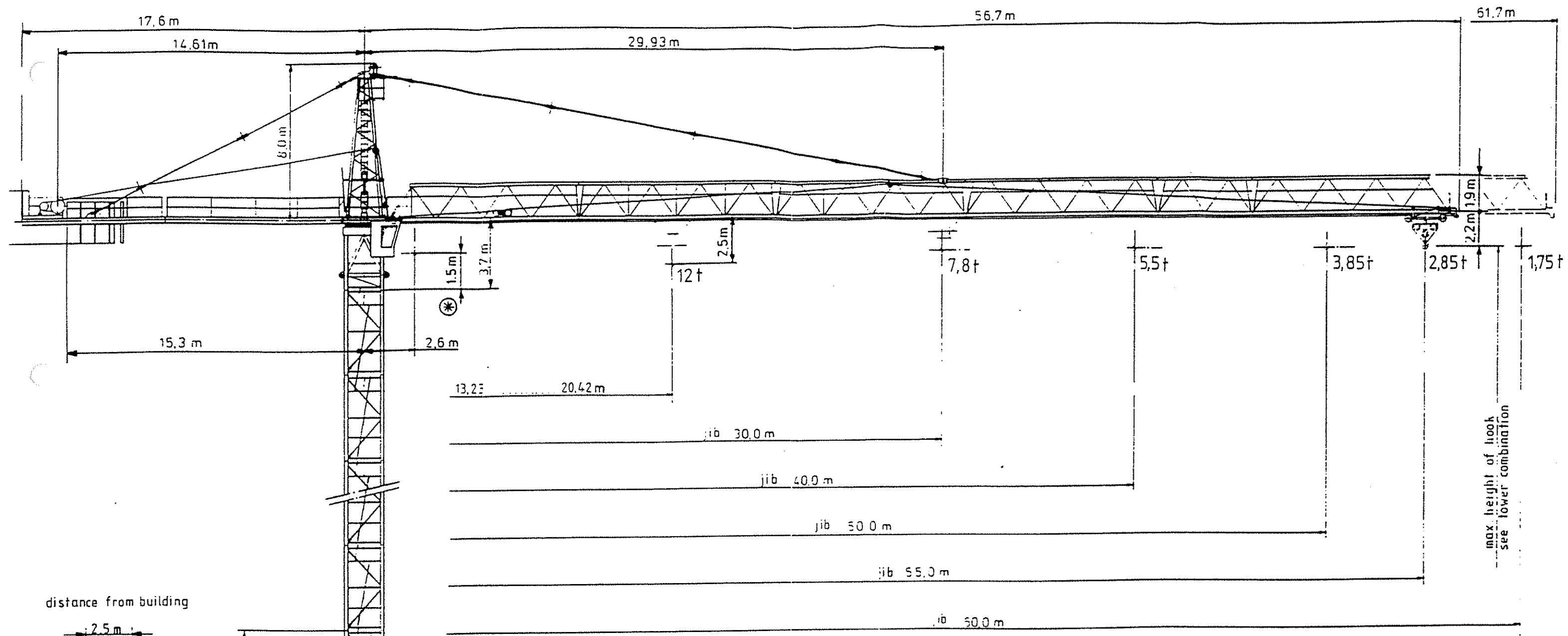

max height of hook
see lower combination

distance from building

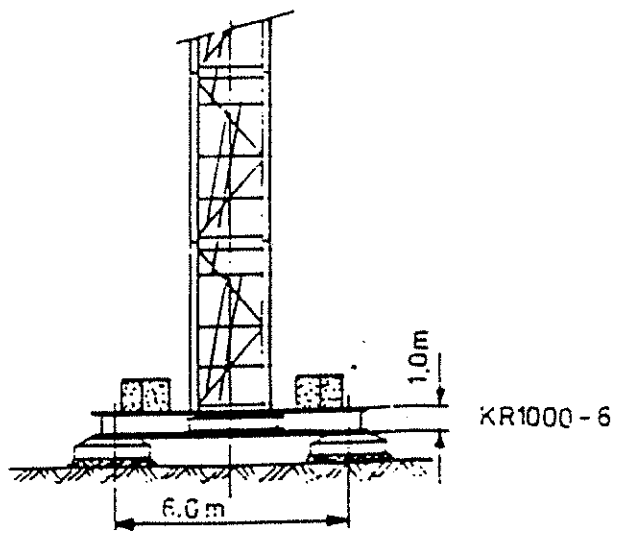
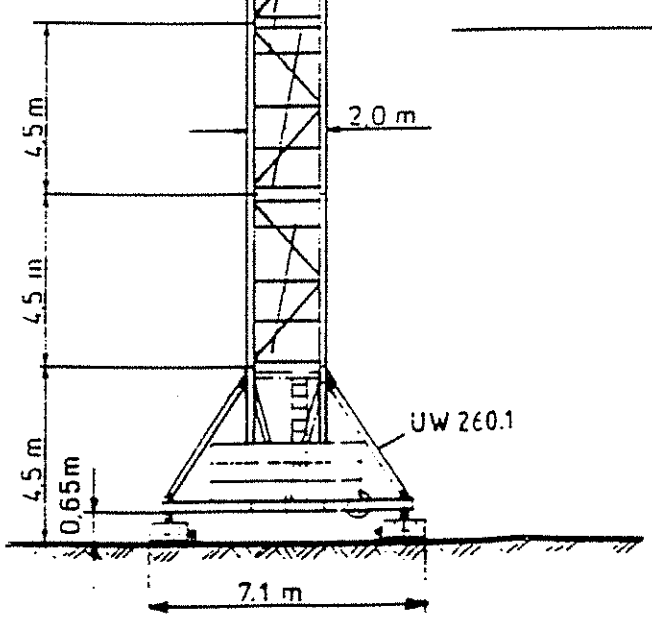
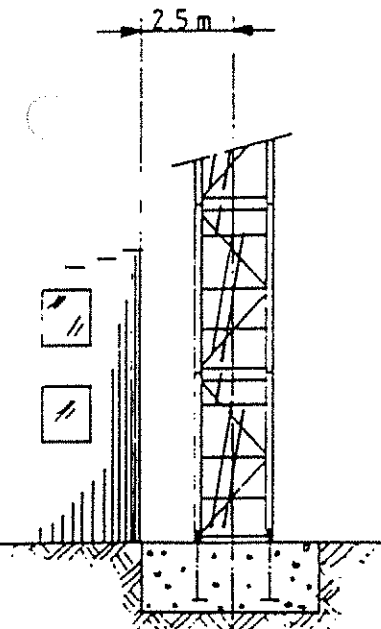

model
kind of crane

WK 200 EC
tower crane with horizontal jib, top-slewing,
self-climbing

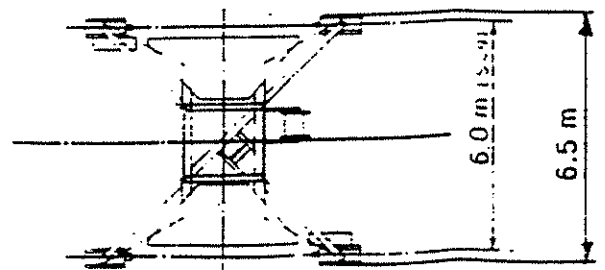

Other undercarriages and crossframes upon request.
* With fourlines height under hook is reduced by 0.3 m.

Wolffkran 200 EC

M 1:200

1982	11.11.	Schwarz	
geänd.	126/886	Schwarz	
1:200	WK 200 EC		XIV13292